



KYN28-12系列
金属铠装移开式开关设备
产品选型手册
PRODUCT CATALOG

产品手册

www.jsyineng.com



江苏亿能电气有限公司
JIANGSU YINENG ELECTRIC CO.,LTD.



公司简介 COMPANY INTRODUCTION

江苏亿能电气集团（亿能集团）是集研发，生产和销售中压环网柜、中低压开关柜、高低压母线槽和电缆桥架等电气产品的大型高新技术企业。集团公司成立于2002年，注册资本10088万元，现有员工500多人，坐落在誉为中国工程电气岛——江苏省扬中市经济开发区。

集团公司先后通过了ISO9001质量管理、ISO14001环境管理、OHSAS18001职业健康安全管理、ISO10012测量管理等体系管理认证以及3C和KEMA产品认证。荣获了“国家守合同重信用企业”、“国家高新技术企业”、“江苏省著名商标”，“江苏省名牌产品”等荣誉称号。

集团先后与国际知名公司ABB, Eaton、Siemens、Schneider等签订了战略合作协议。亿能集团生产的开关柜、配电箱、母线槽和桥架广泛应用于国家电网、地铁、石油化工、汽车、电信等领域。过硬的质量，完善的服务赢得了一致好评。

亿能集团在全国十多个城市设立了办事处，配备专职人员，为本地区项目提供及时准确的售前售后服务。

在开拓国内市场的同时，集团注重了国际市场的开发，亿能产品先后应用于十几个国家的重点项目。国际市场将是亿能未来发展的重点方向。

“科技、人文、责任”是亿能的核心价值观，借助品牌管理、提高产品质量、更好地服务于社会是亿能的一贯追求。亿能正朝着中国著名电气企业的方向阔步奋进。

Jiangsu Yineng Electric Group (Yineng Group) is a large private company, which integrates R&D, production and sales of medium-voltage ring main unit, low-voltage switchgear, high and low voltage busbar, cable tray and other electrical products. The group, established in 2002, with the registered capital of more than 100 million Yuan and the employee of more than 500 people, lies in the Economic Development Zone of Yangzhong city, which is well known in China for the concentration of electrical equipment manufacture.

The group has obtained the system certification for ISO9001 Quality Management, ISO14001 Environmental Management, OHSAS18001 Health Management, ISO10012 Measurement Management and product certification of 3C and KEMA. What's more, the Group has won the reputation of "Contract and Accredited Honoring Company", "China's High-tech Enterprise", "Jiangsu Provincial Famous Trademark", and "Jiangsu Famous Product" etc.

The Group has signed the strategic cooperation agreement with great corporations——ABB, Eaton, Siemens, Schneider. The ring main unit, distribution box, busbar and cable tray, which are widely used in State Grid, Subway, Petrochemical, Automobile, Telecommunication and other fields, have got unanimous praise for excellent quality and perfect service,

Yineng Group has established in some big cities in China more than ten offices with full time staff to provide timely and accurate pre-sale and after-sale service for the districts.

Jiangsu Yineng Group is focusing on the development of international market at the same time of opening up the domestic market. The products have been applied in more than a dozen foreign projects. Opening up the international market will be one of the main development directions of Yineng in the future.

"Technology, Humanity, Responsibility" is the core values of Yineng. The consistent pursuit of the group is to improve the quality of products and the service to the society with the help of brand management. Yineng is moving on rapidly in the direction of being China's famous electric enterprise.



型号及含义
Type and Designation 1

使用环境
Operating Conditions 2

特点
Characteristic 3

技术参数
Technical Data 4

结构介绍
Construction 5

主要元件
Main Components 6

一次方案
Primary Schemes 7

安装
Installation 8

订货须知
Ordering Information 9

1 型号及含义 Type and Designation

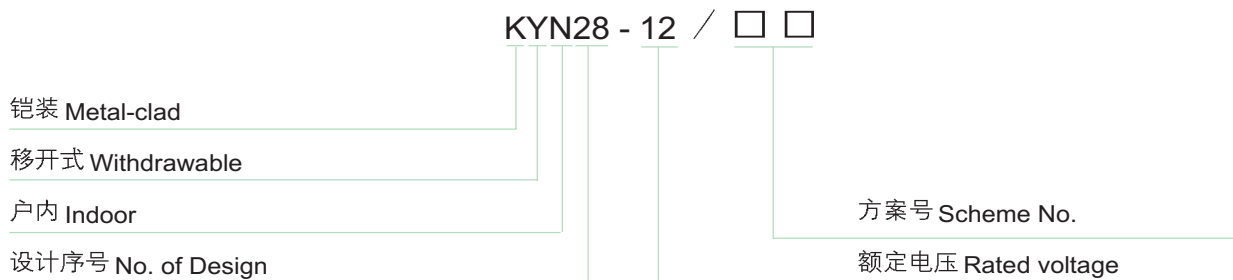

2 使用环境 Operating Conditions

- 环境温度：上限 +40℃ ； 下限 -10℃ ；
 - 海拔高度：不超过 1000m ；
 - 相对湿度：日平均值 ≤ 95%，月平均值 ≤ 90% ；
 - 地震烈度：不超过 8 度。
 - 没有火灾，爆炸危险，严重污秽，化学腐蚀及剧烈振动的场所。
- 注：超出上述环境条件时，请与制造商协商。
- Ambient temperature: max. to +40℃ min. to -10℃ .
 - Altitude: 1000m(max).
 - Relative humidity: daily average less than 95%, monthly less than 90%.
 - Shock of earthquake: less than 8 magnitude.
 - This product should not be used under conditions of fire, explosion, earthquake and chemical corrosion environments.
- Note:** Special condition and requirement, consult with the manufacturer.

3 特点 Characteristic

- 完全金属铠装及封闭，能有效地防止事故扩散。
 - 低压部分和高压部分完全隔离。
 - 关门后防护等级达 IP4X，可有效防止人体和外界固体接近带电体和运动部分，保证人身安全和设备可靠运行。
 - 简单而有效的联锁，防止误操作。
 - 电缆室有充裕的空间，可连接多根电缆，安装，维修方便。
 - 手车互换性好，更换断路器非常简便。
- Metal-clad and partition completely, effectively prevent faults spreading.
 - The low voltage section is completely separated from the high voltage sections.
 - Enclosure protection degree is IP4X, protect against electric shock and ingress of solid foreign bodies.
 - Simple but effective interlocking prevents maloperation.
 - Space is provided for multiple cable connections. Installation and maintenance is convenient.
 - Withdrawable part of the same design are mutually interchangeable, an exchange of VCB is very simple.



技术参数 Technical data

	单位 Unit	数据 Data			
		断路器柜 VCB switchgear		F-C 柜 F-C switchgear	
额定电压 Rated voltage	kV	7.2	12	7.2	12
1min工频耐压 Rated power-frequency withstand voltage (1min)	kV	32	42	32	42
雷电冲击耐压 Rated lightning impulse withstand voltage	kV	60	75	60	75
额定频率 Rated frequency	Hz	50		50	
主母线额定电流 Main busbar rated current	A	...4000		...4000	
分支母线额定电流 Branchal busbar rated current	A	...4000*		...400	
额定短时耐受电流(有效值)4秒**Rated short-time withstand current (rms),4s	kA	...40		4kA/4s	
额定峰值耐受电流(峰值)**Rated peak withstand current (peak)	kA	...100		10	
外壳防护等级 Enclosure protection level		IP4X		IP4X	

*: 3150A 及以上断路器室采取强迫风冷

Enforced cooling is necessary when the current is over and including 3150A of VCB

**：电流互感器的热稳定和动稳定电流与变化有关，在订货时作具体确认。

Rated short-time withstand current and rated peak withstand current of current transformers are relate to rated transformers are relate to rated transformation ratio, affirm when ordering.

外形尺寸和重量 Outline dimensions & weight

高度 Height	2200mm	
宽度 Width	额定电流 1250A 及以下 Rated current down to 1250A	800.(650*) mm
	额定电流 1600A 及以上 Rated current up to 1600A	1000 mm
深度 Depth	柜前维护 Front maintenance	1350 mm
	双面维护 Double-face maintenace	1500/1560 mm
F-C柜switchgear (宽W x 高H x 深D)	650 x 2200 x 1560mm	
重量 Weight	800~1200kg	

*: 此尺寸配VD4断路器时可采用。 Suitable for VD4 being equipped.



本开关柜由柜体和手车两大部分组成。

柜体是由螺栓组装而成,其外壳和内部隔板采用防腐钢板。柜体由四个不同的功能单元组成,分别是手车室、母线室、电缆室、低压室。柜体有两种结构:柜前维护结构、双面维护结构。

可移开单元根据用途可分为:

- 断路器手车
- 电压互感器手车
- 隔离手车
- 计量手车
- 熔断路手车等

The basic structure of the switchgear panel comprises the panle itself and withdrawable part.

The panel is constructed by bolting together. Enclosure and internal partition are of anticorrosive steel sheets.

The panel consists of four separate compartments, that is truck compartment, busbar compartment, cable compartment, low-voltage maintenance type, double-face maintenance type. Withdrawable part can be classified

by function to:

- VCB truck
- PT turck
- Disconnect truck
- Metering truck
- HV fuse truck etc

柜前维修型柜内结构示意图
(配常规电流互感器)
Section view, front maintenance structure
(with normal current transformer)

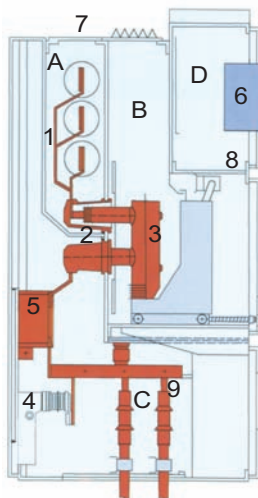

- A. 母线室 Busbar compartment
- B. 断路器室 Truck compartment
- C. 电缆终端室 Cable compartment
- D. 低压室 Low-voltage compartment
- 1. 母线 Busbar
- 2. 静触头盒 Bush
- 3. 断路器 VCB
- 4. 接地开关 Earthing switch
- 5. 电流互感器 Current transformer
- 6. 控制和保护单元 Control and protect unit
- 7. 压力释放板 Pressure-relief plate
- 8. 二次插头 Control wiring plug
- 9. 电缆终端 Cable terminal

柜前维修型柜内结构示意图
(配套管式电流互感器)
Section view, front maintenance structure
(with bushing-type current transformer)

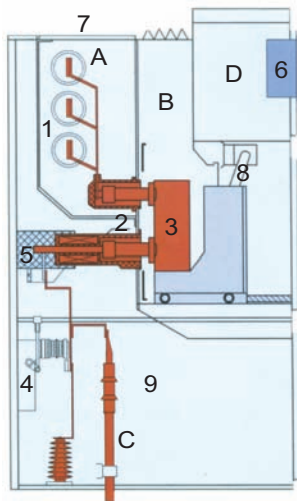

- A. 母线室 Busbar compartment
- B. 断路器室 Truck compartment
- C. 电缆终端室 Cable compartment
- D. 低压室 Low-voltage compartment
- 1. 母线 Busbar
- 2. 静触头盒(与互感器一体式) Bush
- 3. 断路器 VCB
- 4. 接地开关 Earthing switch
- 5. 转接件 Connector
- 6. 控制和保护单元 Control and protect unit
- 7. 压力释放板 Pressure-relief plate
- 8. 二次插头 Control wiring plug
- 9. 电缆终端 Cable terminal

双面维修型柜内结构示意图
Section view, double maintenance structure

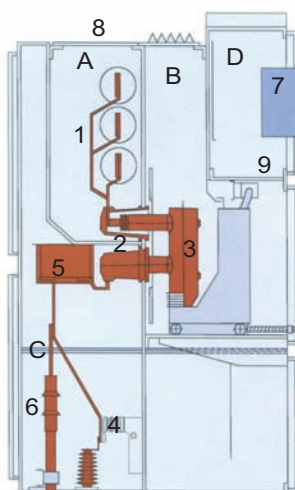

- A. 母线室 Busbar compartment
- B. 断路器室 Truck compartment
- C. 电缆终端室 Cable compartment
- D. 低压室 Low-voltage compartment
- 1. 母线 Busbar
- 2. 静触头盒 Bush
- 3. 断路器 VCB
- 4. 接地开关 Earthing switch
- 5. 电流互感器 Current transformer
- 6. 电缆终端 Cable terminal
- 7. 控制和保护单元 Control and protect unit
- 8. 压力释放板 Pressure-relief plate
- 9. 二次插头 Control wiring plug

手车室

Truck compartment

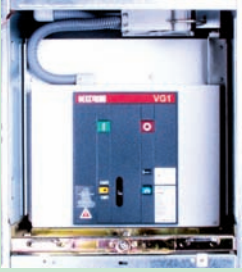

■ 手车室安装了导轨，确保手车在柜内平衡、可靠的移动。

■ 金属活门，随手车进出自动打开和关闭。且上下活门可分别打开，方便操作和维护并确保人身安全。

■ 手车室门关闭时可操作手车，通过视察窗可观察到手车所处位置，断路器的合分指示和储能状态指示。

■ Accommodate special guide rails to move truck smoothly and reliably.

■ Metal shutters open/close automatically with the truck

move in/out. Each shutter can be opened independently of one another. It is convenient to operate and maintain, ensure personal safety.

■ The truck can be operated with the door closed. Truck position, VCB ON/OFF indicator and charge condition indicator could be observed through window.

电缆室

Cable compartment

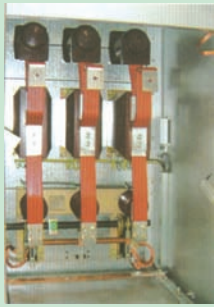

■ 可连接

单芯电缆，每相最多可接六根电缆

三芯电缆，每相最多可接三根电缆

■ 电缆连接高度在 650mm 以上。

■ 可选择的元件：

电流互感器，电压互感器，快速接地开关，避雷器，零序电流互感器，带电显示器

■ Connection

single-core cable max. six cables per phase.

three-core cable max. two cables per phase.

■ The height for mounting cable sealing ends is higher than 650mm.

■ Optional parts:

current transformer, voltage transformer, make-proof earthing switch, Surge arrester, Residual current transformer, voltage indicator.

母线室

Busbar compartment



■ 根据额定电流大小，主母线选用 1-3 根铜排。

■ 相邻母线室之间用套管和金属隔板隔离，能有效防止事故蔓延。

■ 主母线及分支母线均用热缩绝缘套覆盖。

■ According to the current the busbar can be one to three pieces.

■ Panels are divided by inter-panel bushings and bushing plate to prevent transfer of faults between panels.

■ Busbars and tee-off conductors are insulated by means of shrink-on sleeves.

低压室

Low-voltage compartment



- 低压室及其门板可根据不同要求安装各种二次设备。
- 控制母线安装在低压室顶板上,并用可旋转的隔板盖住,方便现场安装。
- Can install various auxiliary equipments on request.
- Control busbar is installed on top of the compartment and covered with rotary steelsheet.

联锁

Interlocks

KYN28-12开关柜具有一系列联锁装置,从根本上防止出现危险局面和可能引起严重后果的操作,从而有效保证了操作运行人员以及开关柜本身的安全。开关柜在进行下列操作时,需满足有关联锁条件,否则操作将被阻止。

- 把手车部分从试验位置进到工作位置:

断路器或接触器在“分”位置

接地开关在“分”位置

- 把手车部分从工作位置退出到试验位置:

断路器或接触器在“分”位置

- 操作断路器或接触器:

手车被锁定在试验位置或工作位置

- 操作接地开关:

手车部分锁定在试验位置

电缆室门关闭

A series of interlocks to prevent maloperation, thus protecting both personnel and the switchgear itself.

The following operations can take place as the stated interlock conditions are fulfilled, otherwise operations must be blocked.

- Move the withdrawable part from the test position to the service position

VCB or VC in the OPEN position

earthing switch in the OPEN position

- Move the withdrawable part from the service position to the test position

VCB or VC in the OPEN position

- Operate the VCB or VC

withdrawable part have been locked in the test position or the service position

- Operate the earthing switch

withdrawable part have been locked in the test position
cable compartment door closed

KYN28-12

VG1(ZN63B-12)型真空断路器的主要技术参数 Technical data of VCB VG1(ZN63B-12)



额定电压 Rated voltage	kV	12				
额定电流 Rated current	A	630,1250	630,1250, 1600,2000	1250,1600, 2000,3150*,4000*		
额定频率 Rated frequency	Hz	50				
额定短路开断电流(有效值) Rated short-circuit breaking current (rms.)	kA	20	25	31.5	40	50
额定短路关合电流(有效值) Rated short-circuit making current (peak)	kA	50	63	80	100	125
额定热稳定电流/4s Rated short-time withstand current/4s	kA	20	25	31.5	40	50
额定动稳定电流 Rated peak withstand current/4s	kA	50	63	80	100	125
额定短路电流开断次数 Rated operations of short-circuit current breaking	次 operations	50**				
1min 工频耐压 Rated power-frequency withstand voltage (1min)	kV	42				
雷电冲击耐压 Rated lightning impulse withstand voltage	kV	75				
额定单个电容器组开断电流 Rated single capacitor bank breaking current	A	630				
额定背对背电容器组开断电流 Rated back-to-back capacitor bank breaking current	A	400				
额定电容器组关合涌流 Rated capacitor bank inrush making current	kA	12.5 (f<1000Hz)				
开断电流直流分量百分比 Percentage of d.c. component of breaking current		50%***				
额定操作顺序 Rated operating sequence		O—0.3s—CO—180s—CO (≤31.5kA) O—180s—CO—180s—CO (≥40kA)				

* 3150A,4000A 强迫风冷 3150A,4000A enforced cooling

** ≥40kA,30次 Operations

*** ≥40kA,40%

VD4型真空断路器的主要技术参数 Technical data of VCB VD4



额定电压 Rated voltage	kV	12
额定电流 Rated current	A	...4000*
额定频率 Rated frequency	Hz	50
额定短路开断电流 Rated short-circuit breaking current	kA	...50
额定短路关合电流 (峰值) Rated short-circuit making current (peak)	kA	...125
额定短时耐受电流 (峰值) 3秒** Rated short-time withstand current (rms) 3s	kA	...50
额定峰值耐受电流 (峰值) Rated peak withstand current (peak)	kA	...125
1min 工频耐压 Rated power-frequency withstand voltage (1min)	kV	42
雷电冲击耐压 Rated lightning impulse withstand voltage	kV	75
额定操作顺序 Rated operating sequence	O—0.3s—CO—180s—CO ($\leq 31.5\text{kA}$) O—180s—CO—180s—CO ($\geq 40\text{kA}$)	

* 采取强迫风冷却措施 Enforced cooling

**：31.5kA 以下为 4 秒

KYN28-12

方案编号 Scheme No.		1	2	3	4	5
主结线方案 Single-line diagram						
额定电流 (A)		...4000	...4000	...4000	...4000	...3150
主要元件 Main Components	真空断路器 VCB (VG1,VD4)	1	1	1	1	1
	电流互感器 CT (LZZBJ9)	3	3	3	3	3
	电压互感器 PT (JDZ10)					
	高压熔断器 HV fuse (XRNP)					
	接地开关 Earthing switch (JN15-12)					1
	避雷器 Surge arrester (YH5W)			3		3
	零序互感器 Residual CT (LXK)	按用户需要	按用户需要			按用户需要
带电显示器 Voltage indicator (DXN8B)	1	1	1	1	1	

方案编号 Scheme No.		6	7	8	9	10
主结线方案 Single-line diagram						
额定电流 (A)		...3150	...3150	...1250		
主要元件 Main Components	真空断路器 VCB (VG1,VD4)	1	1	1		
	电流互感器 CT (LZZBJ9)	3	3	3		
	电压互感器 PT (JDZ10,JSZVR2-10)		2	2/1		
	高压熔断器 HV fuse (XRNP)		3	3		
	接地开关 Earthing switch (JN15-12)					
	避雷器 Surge arrester (YH5W)	3				
	零序互感器 Residual CT (LXK)	按用户需要	按用户需要	按用户需要		
带电显示器 Voltage indicator (DXN8B)	1	1	1			

方案编号 Scheme No.		11	12	13	14	15
主结线方案 Single-line diagram						
额定电流 (A)		...4000	...4000	...4000	...1250	
主要元件 Main Components	真空断路器 VCB (VG1,VD4)					
	电流互感器 CT (LZZBJ9)					
	电压互感器 PT (JDZ10,JSZVR2-10)				2/1	
	高压熔断器 HV fuse (XRNP)				3	
	消谐器 LXQ					
	避雷器 Surge arrester (YH5W)					
	零序互感器 Residual CT (LXK)	按用户需要			按用户需要	
带电显示器 Voltage indicator (DXN8B)	1	1	1	1		

方案编号 Scheme No.		16	17	18	19	20
主结线方案 Single-line diagram						
额定电流 (A)						
主要元件 Main Components	真空断路器 VCB (VG1,VD4)					
	电流互感器 CT (LZZBJ9)					
	电压互感器 PT (JDZ10)	2	3	3	2	3
	高压熔断器 HV fuse (XRNP)	3	3	3	3	3
	消谐器 LXQ		1			
	避雷器 Surge arrester (YH5W)	3	3	3	3	3
	零序互感器 Residual CT (LXK)					
带电显示器 Voltage indicator (DXN8B)	1	1	1	1	1	

方案编号 Scheme No.		21	22	23	24	25
主结线方案 Single-line diagram						
额定电流 (A)						
主要元件 Main Components	变压器 Transformer SC9					1
	电流互感器CT (LZZBJ9)	2	2			
	电压互感器PT (JDZ10)	2	2			
	高压熔断器 HV fuse (XRNP)	3	3			
	接地开头 Earthing switch (JN15-12)					
	避雷器 Surge arrester (YH5W)				3	
	零序互感器 Residual CT (LXK)					按用户需要
	带电显示器 Voltage indicator (DXN8B)	1	1		1	1

方案编号 Scheme No.		26	27	28	29	30
主结线方案 Single-line diagram						
额定电流 (A)		...315	...315			
主要元件 Main Components	真空断路器 VC (3TL6,JCZ5)	1	1			
	熔断器 HV fuse (XRNM1-6WKN)	3	3			
	避雷器 Surge arrester (YH2.5W)	3	3			
	电流互感器CT (LZZBJ9)	3	3			
	零序互感器 Residual CT (LXK)	按用户需要	按用户需要			
	接地开头 Earthing switch (JN15)	1				
	带电显示器 Voltage indicator (DXN8B)	1	1			

开关柜外形尺寸示意图

Sketch of overall dimensions for switchgear

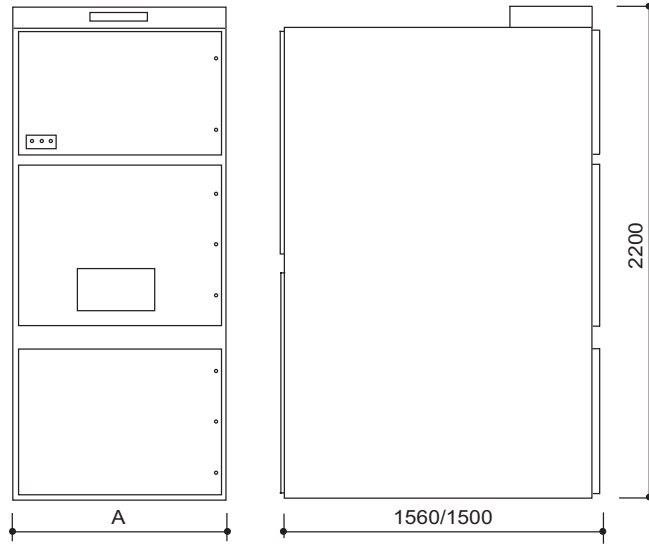

开关柜参数 Technical Data	尺寸 A Dimension
额定电流至 1250A Rated current up to 1250A	800
额定电流大于 1250 至 4000A Rated current over 1250 to 4000A	1000
所用变至 30kVA Transformer up to 30kVA	1000
F-C 柜 F-C Switchgear	650/800

开关柜单列布置示意图

Sketch of switchgears installation details



开关柜对列布置及母线桥示意图

Sketch of switchgears installed face to face and busbar bridge

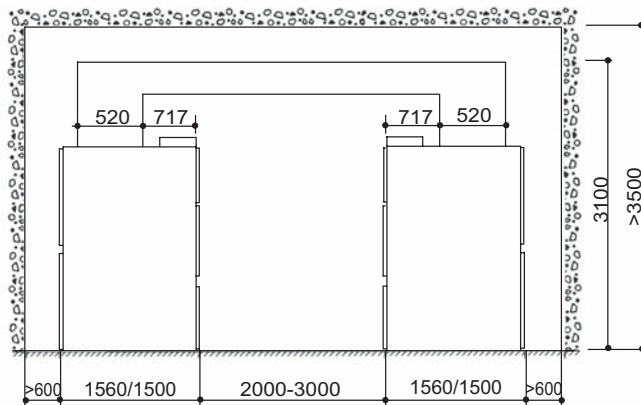

KYN28-12 安装基础示意图 (深为 1500mm) Sketch of KYN28-12 installing foundation (depth 1500mm)

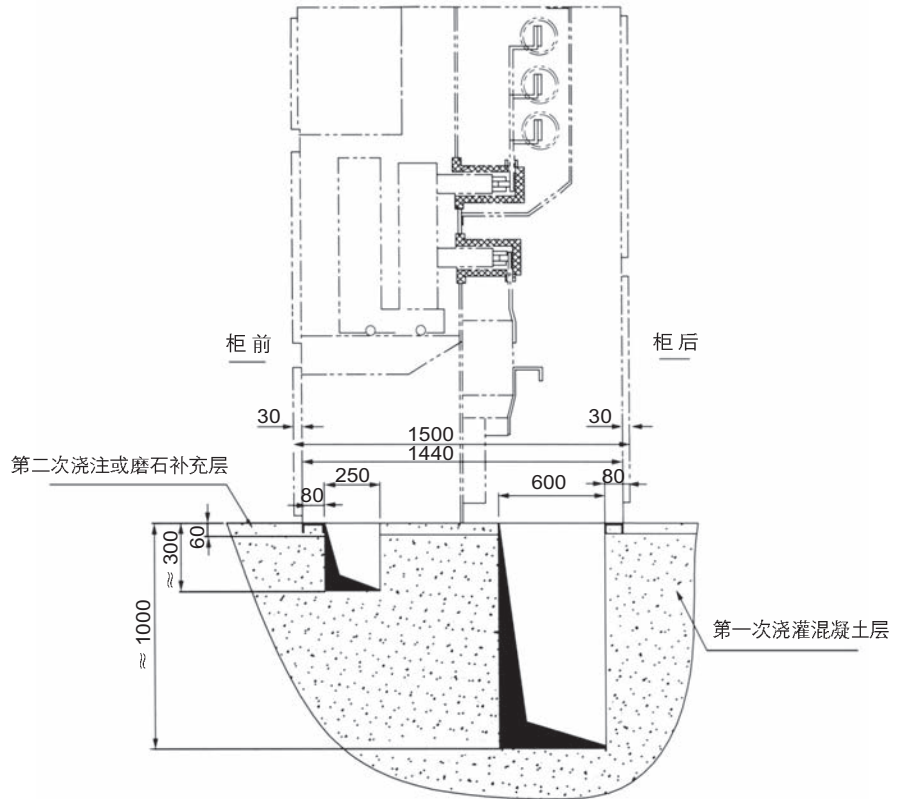

KYN28-12 地板开孔及固定点 (深为 1500mm) Sketch of KYN28-12 floor cutouts and fixpoints (depth 1500mm)

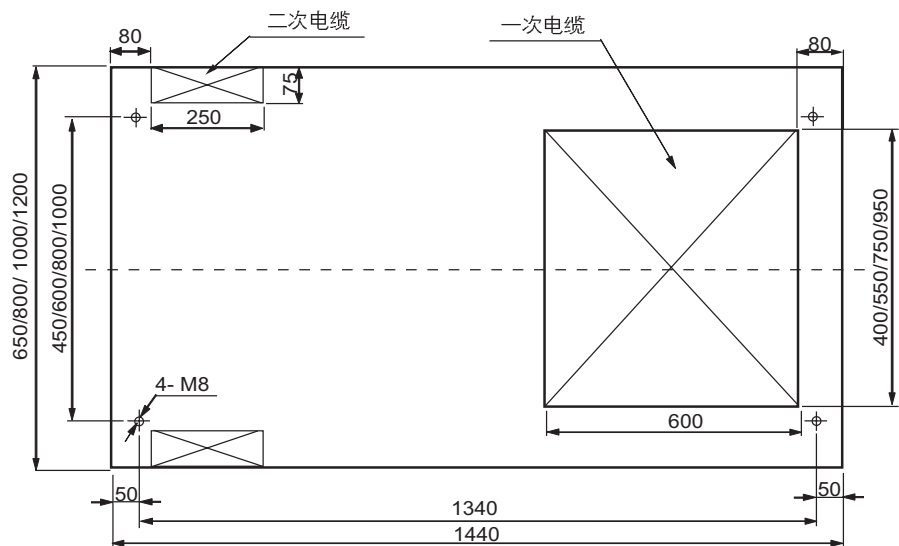

KYN28-12 安装基础示意图 (深为 1560mm) Sketch of KYN28-12 installing foundation(depth 1560mm)

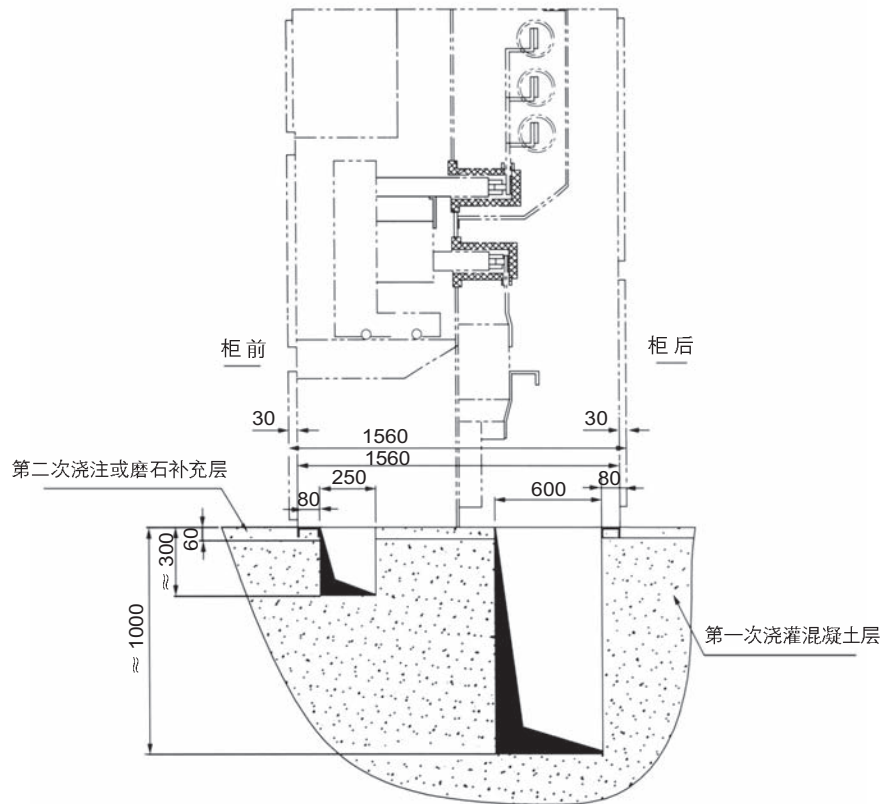

KYN28-12 地板开孔及固定点(深为 1560mm) Sketch of KYN28-12 floor cutouts and fix points(depth 1560mm)

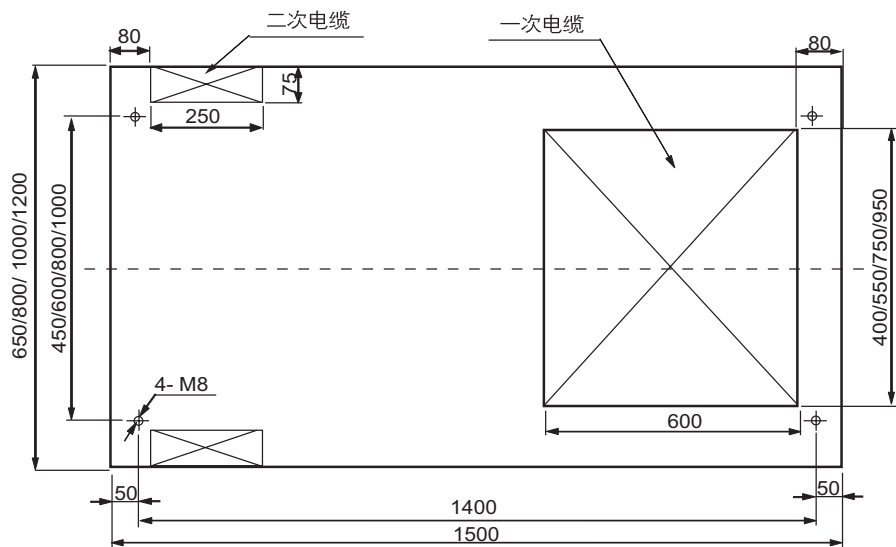

KYN28-12 安装基础示意图 (深为 1350mm) | Sketch of KYN28-12 installing foundation (depth 1350mm)

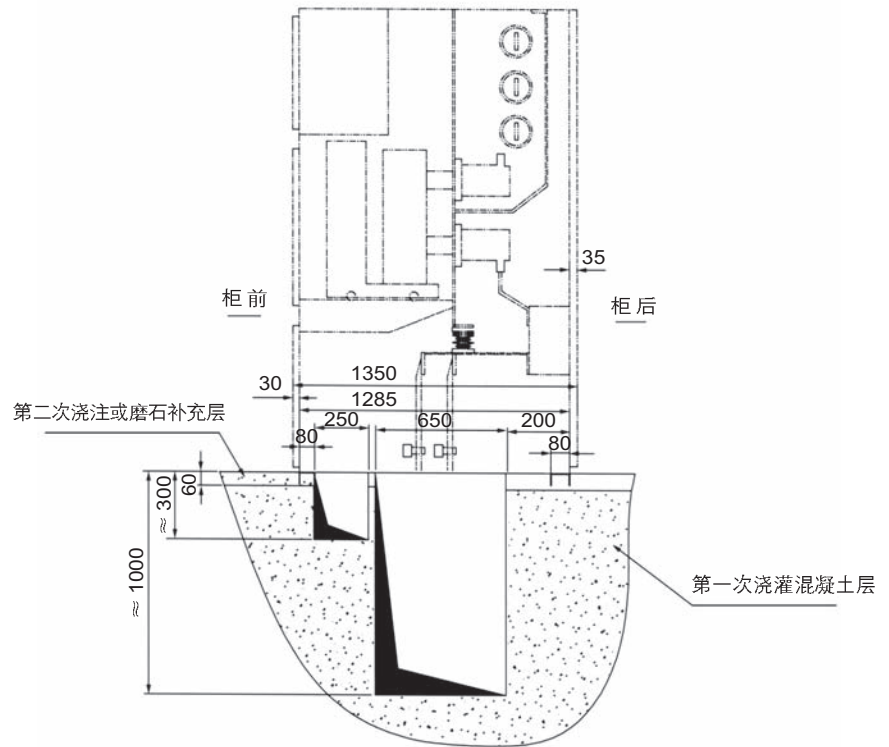

KYN28-12 地板开孔及固定点 (深为 1350mm) | Sketch of KYN28-12 floor cutouts and fixpoints (depth 1350mm)

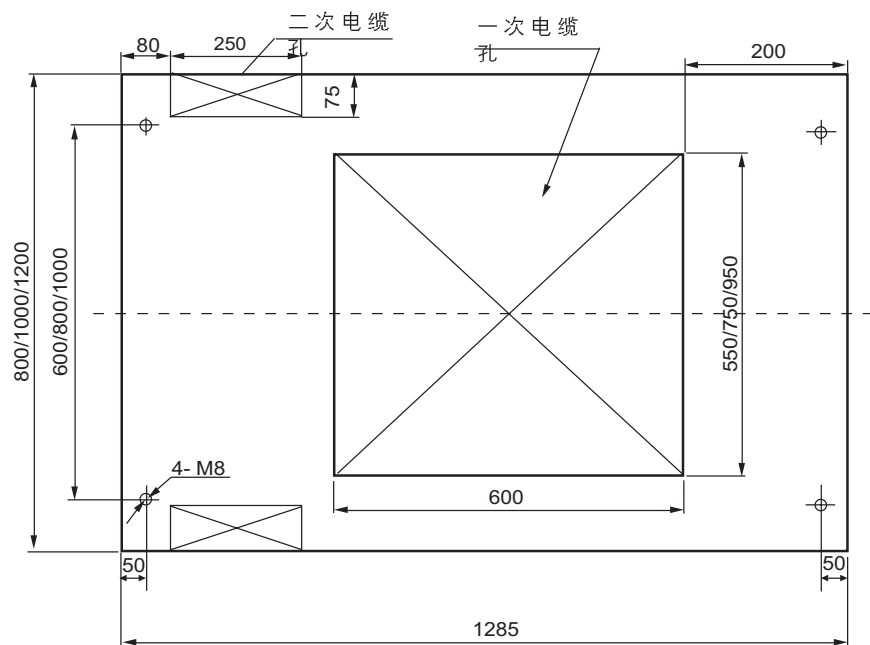

注：括号内尺寸为 1000mm 柜宽尺寸

Note: the dimensions in bracket are for width 1000mm



产品订货须知

Ordering information

用户订货时须提供下列技术资料:

- 一次主结线主案的单线系统图及主母线型号规格。
- 各柜的二次原理图及端子排列图，若无端子排列图则按制造厂编排。
- 二次小母线布置图及小母线形式。
- 配电室平面布置图及相关的剖面图。
- 若需要母线桥（柜间母线桥或墙柜间母线桥，防护等级 IP2X）需提供跨距和高度尺寸。
- 电气设备汇总表。
- 地区性特殊要求及特殊使用环境应在订货时提出。
- 需要其它或超出的附件、备件时，应提出种类及数量。

Customer should provide the following technical data when ordering:

- Drawing of primary scheme and type of main busbar.
- Control circuit drawing and terminal arrangement, otherwise accord to the standards of the manufacture.
- Control busbar arrangement and type.
- Distributing room arrangement and relevant section sketch.
- Dimensions of height and span when needing busbar bridge.
- List of electrical components.
- Special requirment and condition, consult with the manufacturing.
- Type and number when requiring additional or other accessories.



江苏亿能电气有限公司
JIANGSU YINENG ELECTRIC CO.,LTD.

地址：江苏省扬中市港隆路508号(沿江工业集中区)

电话：0511-88455999 88450116

传真：0511-88330556

电邮：yineng@jsyineng.com 邮编：212213